



actual size

Quartz Crystal · MQ1-SMC

SMD Crystal Version · 11.7 x 7.8 mm

- automotive temperature range available
- reflow soldering temperature: 260 °C max.
- package height 3.6 mm max.



RoHS compliant



Pb free: pins / pads

General Data

type	MQ1 (UM-1-SMC)
frequency range	0.9216 / 1.0 MHz (fund. SL-cut)
	4.00 ~ 40.00 MHz (fund. AT-cut)
	20.0 ~ 105.0 MHz (3rd OT AT-cut)
	50.0 ~ 175.0 MHz (5th OT AT-cut)
	70.0 ~ 250.0 MHz (7th OT AT-cut)
frequency tolerance at 25 °C	± 5 ppm ~ ± 30 ppm
load capacitance C_L	12 pF ~ 32 pF or series
shunt capacitance C_0	< 7 pF
storage temperature	-55 °C ~ +125 °C
drive level max.	500 µW (100 µW recommended)
aging	< ± 3 ppm first year

Dimensions

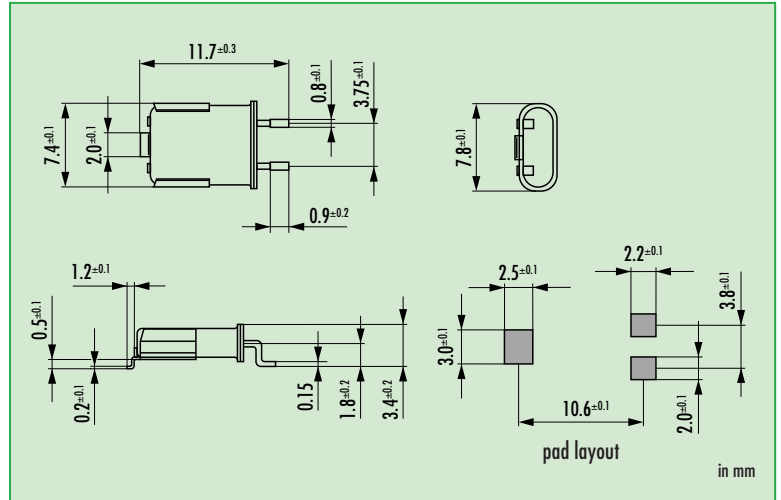

Frequency Stability vs. Temperature

		± 3 ppm	± 5 ppm	± 10 ppm	± 30 ppm	± 50 ppm	± 100 ppm
0 °C ~ +60 °C		○	○	○			
-20 °C ~ +70 °C	STD.		○	○	●		
-40 °C ~ +85 °C	T1			○	○	●	
-40 °C ~ +90 °C	T4				○	○	○
-40 °C ~ +105 °C	T2				○	○	○
-40 °C ~ +125 °C	T3						○

● standard
○ available

ESR (series resistance R_s)

frequency in MHz	vibration mode	ESR max. in Ω	ESR typ. in Ω
0.92 / 1.000	fund.- SL	3000	800
4.00 ~ 4.9999	fund.- AT	150	80
5.00 ~ 9.9999	fund.- AT	80	40
10.0 ~ 14.999	fund.- AT	40	20
15.0 ~ 40.000	fund.- AT	30	15
20.0 ~ 49.999	3rd OT - AT	80	70
50.0 ~ 105.00	3rd OT - AT	60	50
50.0 ~ 175.00	5th OT - AT	150	100
70.0 ~ 250.00	7th OT - AT	100	80

Order Information

Q	frequency	type	load capacitance in pF	stability at 25 °C	stability vs. temp. range	SMD version	option
Quartz	0.9216 ~ 250.0 MHz	MQ1	12 pF ~ 32 pF S for series	± 5 ~ ± 30 ppm	see table	SMC	blank = -20 °C ~ + 70 °C T1 = -40 °C ~ + 85 °C T2 = -40 °C ~ +105 °C T3 = -40 °C ~ +125 °C T4 = -40 °C ~ + 90 °C FU = for fundamental frequencies ≥ 20 MHz 30T = 3rd overtone 50T = 5th overtone 70T = 7th overtone TR = taped

Example: Q 30.0-MQ1-30-30/50-SMC-FU (Suffix LF = RoHS compliant / Pb free pins or pads)



Quartz Crystal · MQ1-SMC

Taping Specification

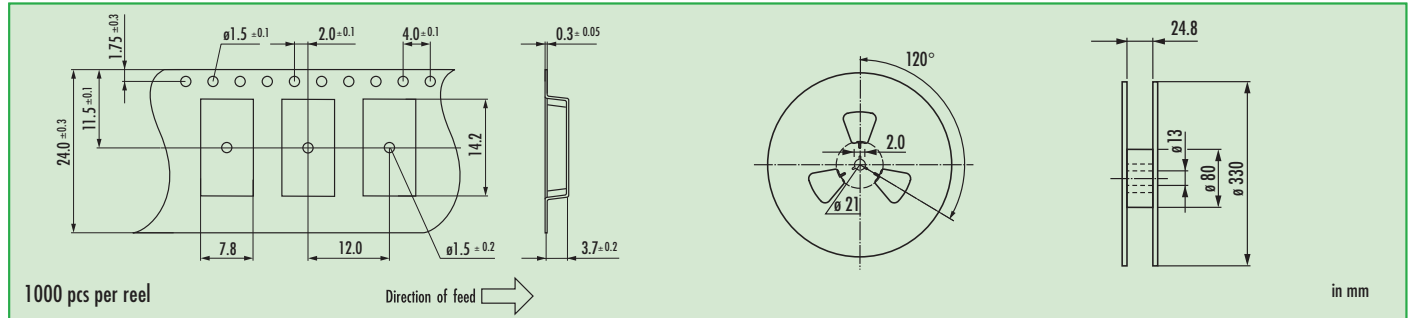

Reflow Soldering Profile

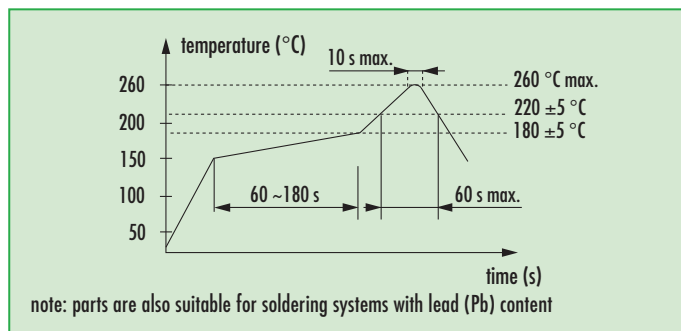

Marking

frequency
company code / date code