

# Quartz Crystal · SS2

Pin Type Crystal · 11.35 x 4.65 mm

- recommended for automotive applications
- wave soldering temperature: 260 °C max.
- package height 2.5 mm max.



## General Data

type		SS2
frequency range	fund. AT-cut	8.0 ~ 33.0 MHz (4.0 ~ 8.0 MHz, ask if available)
	3rd OT AT-cut	ask for availability
	fund. BT-cut	ask for availability
frequency tolerance at 25 °C		± 20 ppm / ± 30 ppm / ± 50 ppm
load capacitance C <sub>L</sub>		12 pF ~ 32 pF or series
shunt capacitance C <sub>0</sub>		< 5 pF
storage temperature		-40 °C ~ +125 °C
shock resistance		> 100 g (half sine pulse, 0.6 ms)
drive level max.		500 µW (100 µW recommended)
aging		< ± 5 ppm first year

## Dimensions

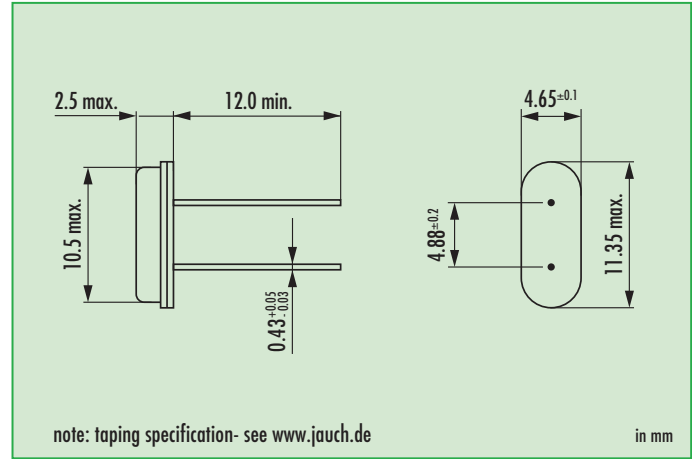

## Frequency Stability vs. Temperature

		± 20 ppm	± 30 ppm	± 50 ppm	± 100 ppm	± 150 ppm	+10/-100 ppm
-20 °C ~ +70 °C	STD	D	○	●			○ BT-cut
-40 °C ~ +85 °C	T1		○	○	●		
-40 °C ~ +105 °C	T2			○	○		
-40 °C ~ +125 °C	T3					○	

● standard  
 ○ available  
 D ask, if available

## ESR (series resistance R<sub>s</sub>)

frequency in MHz	vibration mode	ESR max. in Ω	ESR typ. in Ω
(4.0 ~ 5.999)	fund. AT	(80)	(60)
(6.0 ~ 6.999)	fund. AT	(70)	(35)
(7.0 ~ 7.999)	fund. AT	(50)	(25)
8.0 ~ 8.999	fund. AT	50	25
9.0 ~ 13.999	fund. AT	35	15
14.0 ~ 33.000	fund. AT	30	10
ask	3rd OT AT	(100)	(60)
ask	fund. BT	(50)	(20)

numbers in brackets ( ) only for reference

## Automotive application note

- automotive quartz crystals have superior environmental performance in case of shock, vibration and temperature
- extended operating temperatures up to +125 °C
- production is certified according to: ISO 9001 / TS 16949 / ISO 14001

## Order Information

Q	frequency	type	load capacitance in pF	stability at 25 °C	stability vs. temp. range	option
Quartz	8.0 ~ 33.0 MHz	SS2	12 pF ~ 32 pF S for series	30 = ± 30 ppm std 20 = ± 20 ppm 50 = ± 50 ppm	see table	blank = -20 °C ~ +70 °C T1 = -40 °C ~ +85 °C T2 = -40 °C ~ +105 °C T3 = -40 °C ~ +125 °C FU = for fundamental frequencies ≥ 20 MHz 3OT = 3rd overtone (if available) BT = fundamental BT-cut (if available) TR = taped TA = taped, ammo pack KIS = insulation spacer LL = lead length in mm PT = plastic tray

Example: Q 30.0-SS2-30-30/50-FU-LF (Suffix LF = RoHS compliant / Pb free pins or pads)



# Quartz Crystal · SS2 · Automotive Applications

## Load Capacitance Codes

12 pF: a	18 pF: f	30 pF: .
13 pF: v	20 pF: c	32 pF: e
14 pF: x	22 pF: g	series: s
15 pF: j	24 pF: d	T: 3rd OT
16 pF: b	25 pF: r	
17 pF: t	27 pF: w	

example 4.0 MHz / 12 pF: 4a000

## Wave Soldering Profile

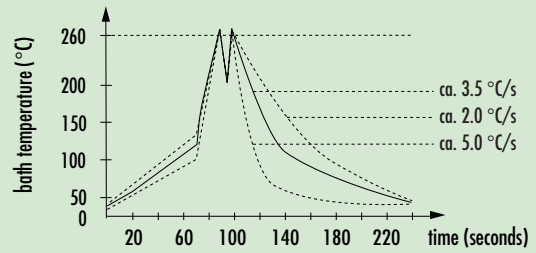

## Taping Specification

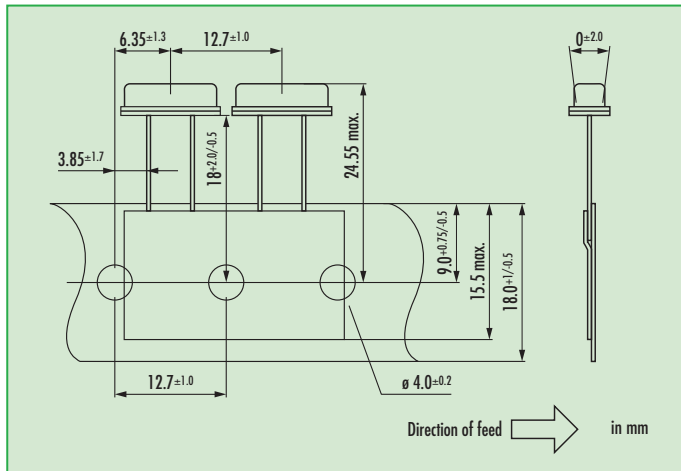

## Marking

frequency with load capacitance code  
company code / date code / internal code

		Jan.	Feb.	Mar.	Apr.	May	Jun.	Jul.	Aug.	Sept.	Oct.	Nov.	Dec.
2011	2015	a	b	c	d	e	f	g	h	i	k	l	m
2012	2016	n	p	q	r	s	t	u	v	w	x	y	z
2013	2017	A	B	C	D	E	F	G	H	J	K	L	M
2014	2018	N	P	Q	R	S	T	U	V	W	X	Y	Z