



actual size

Oscillator · TCXO · JT53C

TCXO with HCMOS output · 5.0 x 3.2 mm

- excellent phase noise
- operating temperature range -40 °C ~ +85 °C
- reflow soldering temperature: 260 °C max.
- ceramic/metal package



General Data

type	JT53C	
frequency range	4.0 ~ 54.0 MHz	
frequency stability	at +25 °C	± 0.5 ppm
	temperature	± 2.5 ppm (others on request)
	aging first year	± 1.0 ppm
	supply voltage	± 0.2 ppm (at V _{DC} ± 5%)
	load change	± 0.2 ppm
	after reflow	± 1.0 ppm
current consumption max.	→ see table 1	
supply voltage V _{DC}	1.8 / 2.5 / 2.8 / 3.3 (± 5%)	
temperature	operating	-30 °C ~ +75 °C / -40 °C ~ +85 °C
	storage	-40 °C ~ +125 °C
output	rise & fall time	5.0 ns max.
	load max.	15 pF
	current max.	4.0 mA
	low level max.	0.1 x V _{DC}
	high level min.	0.9 x V _{DC}
harmonics distortion max.	-5.0 dBc	
symmetry at 0.5 x V _{DC}	45% ~ 55% max.	
start-up time max.	10 ms	
standby current max.	10 µA	
output enable time max.	10 ms	
output disable time max.	250 ns	
Jitter 1 σ	3.0 ps	
phase noise at 10 kHz offset	-145 dBc/Hz	

Table 1: Current Consumption max.

	4 ~ 10 MHz	~ 20 MHz	~ 30 MHz	~ 40 MHz	~ 54 MHz
1.8 V	3.1 mA	3.7 mA	4.2 mA	4.6 mA	5.5 mA
2.5 V	3.1 mA	3.7 mA	4.2 mA	4.6 mA	5.5 mA
2.8 V	3.4 mA	4.1 mA	4.7 mA	5.2 mA	6.0 mA
3.3 V	4.0 mA	4.8 mA	5.5 mA	6.0 mA	7.0 mA

Enable / Disable Function

pin #1 (e/d control)	pin #3 (output)
open	active
high "1" (V _{IH} ≥ 0.7 V _{DC})	active
low "0" (V _{IL} ≤ 0.3 V _{DC})	high impedance
stop function:	
<ul style="list-style-type: none"> • oscillator stops • output high impedance 	

Note

4 user pins (e/d, GND, output, V_{DC})
leave the other pins unconnected!

Dimensions

TCXO
JT53C
1: e/d
2: GND
3: output
4: V_{DC}

pin connection in mm

Order Information

0	frequency in MHz	type	frequency stability code	operating temp. code	supply voltage
Oscillator	4.0 ~ 54.0 MHz	JT53C = TCXO	A = ± 2.5 ppm	G = -30 °C ~ +75 °C K = -40 °C ~ +85 °C	1.8 = 1.8 V 2.5 = 2.5 V 2.8 = 2.8 V 3.3 = 3.3 V

Example: O 16.3680-JT53C-A-K-3.3-LF (Suffix LF = RoHS compliant / Pb free pads)



Oscillator · TCXO · JT53C

Taping Specification

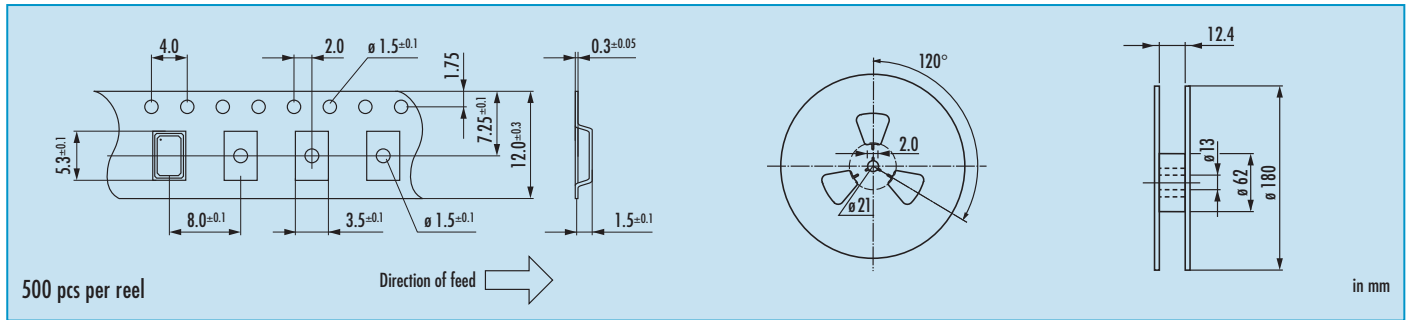

Reflow Soldering Profile

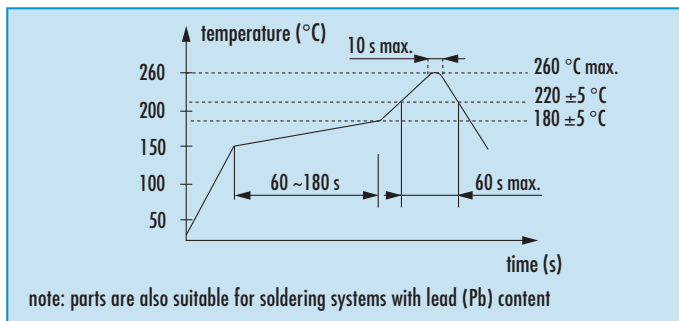

Marking

frequency

company code / stability code / date code (YM)

date code:

A ~ M: Jan. - Dec.

9: 2009

0: 2010

1: 2011

Jan.	Febr.	Mar.	Apr.	May	June
A	B	C	D	E	F
July	Aug.	Sept.	Oct.	Nov.	Dec.
G	H	J	K	L	M

Packing Note

- standard packing units are 500 pieces per reel
- non-multiple packing units are only supplied taped / bulk